

# TAN TIME

# SYSTEM™



## TanTime™ System™ OEM Timer For Sun Capsule Hookup Instructions

**Digital Tanning Bed Timer Control Systems  
for Complete Salon Control**

© 2002 EPaD™, Inc. All rights reserved -----

Electronic Programming and Design, Inc. (EPaD™) and the TanTime™ Division retains all ownership rights to all their products, and the contents of this manual. The source code for firmware and the electronic circuitry design are the confidential trade secrets of EPaD™. You may not attempt to decipher, decompile, develop, or otherwise reverse engineer EPaD™ firmware or products. Information necessary to achieve interoperability is furnished upon request.

The information in the manual is furnished for informational use only, is subject to change without notice, and should not be construed as commitment by EPaD™. EPaD™ assumes no responsibility or liability for any errors or inaccuracies that may appear in this manual. No part of this manual may be reproduced, stored in a retrieval system, or transmitted, in any form or by any means, electronic, mechanical, recording, or otherwise, without the express written permission by EPaD™.

Existing artwork or images that you may desire to scan may be protected by copyright law. Be sure to obtain permission for use of existing artwork.

Trademarks: These products carry the trademark of TanTime™ and EPaD™. All the trademarks of component parts used by TanTime™/EPaD™ in the manufacture of these products are the property of the respective owners. The TanTime™ Logo and System™ name and Logo are trademarks of EPaD™. T-Max® and 3A® are registered trademarks of Applied Digital, Inc. (ADI) and are in no way associated with TanTime™. CompuSUN® and Intellitan® are registered trademarks of SunErgoline, inc. and are in no way associated with TanTime™ or EPaD™. All other brand or product names are trademarks or registered trademarks of their respective companies or organizations.

Written, designed, and illustrated by Electronic Programming and Design, Inc. P.O. Box 81163, Seattle, WA 98108, USA.

## **Manufacturers Statement**

### **Limited Warranty, Disclaimer, Limitation of Liability**

EPaD™ warrants its products to be free of manufacturing defects, defects in materials and defects in workmanship for the lifetime of the products. TanTime™ Products are warranted against normal wear and tear for a period of 12 months from the date of initial purchase. This warranty will not be honored if there has been any attempt to tamper with or remove the external seal, which is intended to preclude tampering with this product's digital or other components. This warranty does not cover damage caused by misuse or abuse of this product or by acts of God or accidents or other misuse or improper installation or unauthorized repair or alteration or causes beyond the control of TanTime™. Also not covered by this warranty are claims other than by the original purchaser. Your sole remedy and our sole liability to you shall be to repair or replace particular products at our discretion if it does not meet the requirements of this warranty.

If the product should become defective within the warranty period, upon receipt, TanTime™ will repair or replace the product free of charge, at the option of TanTime™. Customer is responsible for all shipping charges.

EPaD™/TanTime™ and its distributors shall under no circumstances be liable for any damages arising from the use of or the inability to use TanTime™ products or from any loss of revenue or profit, business interruption, or other loss which may arise from the use of TanTime™ products.

**THE WARRANTIES ABOVE ARE EXCLUSIVE AND IN LIEU OF ALL OTHER WARRANTIES, WHETHER EXPRESS OR IMPLIED, INCLUDING THE IMPLIED WARRANTIES OF MERCHANTABILITY AND FITNESS FOR A PARTICULAR PURPOSE.**

# Hookup

## This Manual

It is recommended that you read this manual before unpacking, installing or operating your new TanTime™ System™ Timers. Important information is covered in this manual that will ease installation and ensure trouble-free operation. Failure to follow setup & operation directions could result in damages not covered by the warranty.

## Physical Connections

### Connecting the Bed to the System™ OEM Timer

A 5 wire, gray hookup cable, approximately 6 feet long, is fixed to the Timer. The other end of this cable is fitted with a 5-pin, latching connector that will mate with the bed's connector. This cable provides all power to the timer, all signals between the bed and the timer and access to the bed's remote Start/Stop button.

### Setting the Switch Position (See Figure 1)

The switch on top of the System™ OEM Timer should be in the **Right** (Off) position except when one of the following are true:

- The timer is the last timer of a daisy chain connected to a front room controller and the End Of Line Terminator (SY-EOL™) will not illuminate. Placing the switch to the **Left** (on) position supplies power to the .SY-EOL™
- The timer is to be remotely controlled by another System™ RU-DS™ or SY-TT-1™ timer connected to a remote Master Controller. Placing the switch to the **Left** (on) position supplies power to the Master Controller.
- When using a Third Party Interface (TPI) to use the Timer with a non-daisy-chained front room controller.

### Installing an End of Line Terminator (SY-EOL™)

To start, all OEM System™ Timers must have the switches set to the **Right** (Off) position. The SY-EOL™ is used only in the last bed of a daisy chain connected to a front room controller. This bed would have only one CAT-5 cable coming to it. The SY-EOL™ should be placed in the unused Daisy Chain connector, and the switch on the timer set to the **Right** (Off). If the SY-EOL™ does NOT illuminate when the Front room controller and Timers are powered on, move the switch to the **Left** (On) position where the SY-EOL™ will illuminate.

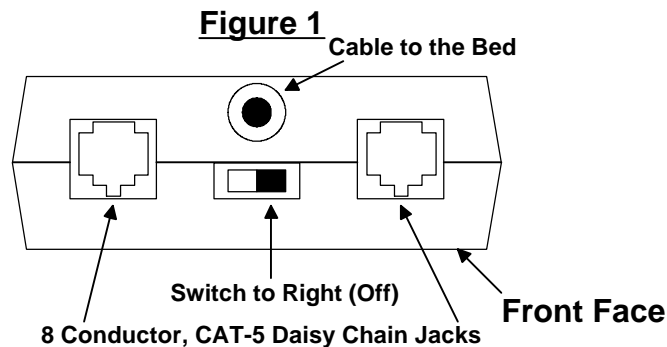

# Hookup

## Connecting to External Controllers

The timer may be operated in a Stand-Alone mode as connected above, or connected to an external controller such as:

- A front room controller from TanTime™, T-Max®, or Intellitan®
- Remote Master Timer from TanTime™ System™, T-Max® or Intellitan® CCS IV®
- Third Party Interface for a front room controller Not from TanTime™, T-Max® or Intellitan® CCS IV®

## Connecting to a System™ Front Room Controller

The System™ OEM Timer may be used with a System™ front room controller using CAT-5 cable. The Timers interconnect in a daisy chain fashion to the controller. The 8 pin modular jacks on the Timer are interchangeable. For use with a TanTime™ TT-40 System™ refer to **Figure 2** and the TT-40 Users' Manual.

If the Timer is the last timer in the daisy chain, install a TanTime™ End Of Line Terminator (SY-EOL™) in the open connector. [See **Installing an End of Line Terminator (SY-EOL™)** above.]

## Connecting to a T-Max® or Intellitan® Front Room Controller or Equivalent

The System™ OEM Timer may be used with a T-Max® or Intellitan® CCS IV® front room controller or equivalent. A TanTime™ SY-MAK™ kit is required to adapt between the Cat-5 cable connections in the System™ timers and 4 line modular jack in the T-Max® or Intellitan® equipment. Interconnect the timers in a daisy chain fashion to the controller. The 8 pin modular jacks on the back of the System™ OEM Timer are interchangeable. Refer to **Figure 3** and the front room controller Users' Manual.

If the System™ timer is the last timer in the daisy chain, install a TanTime™ End Of Line Terminator (SY-EOL™) in the open connector. [See **Installing an End of Line Terminator (SY-EOL™)** above.]

## Operation with Third Party Interface (TPI)

When connecting to a controller Not from TanTime™, T-Max® or Intellitan® CCS IV®, a Third Party Interface (TPI) cable is required (TanTime™ part number SY-TPI.) The TPI cable must be plugged into one of the 8 position modular connectors and the other one must be empty. The Timer switch must be set to the Left (On). The timer must be set to TPI mode as instructed in the Operation Instructions for your System™ OEM timer revision. The timer revision number is shown on the display immediately after power is supplied to the timer. The Operation Instructions are found on the TanTime™ Website, [www.tantime.com](http://www.tantime.com) under Support.

When TPI mode is active, and the TPI cable installed, connecting the two open wires at the end of the TPI cable together will start a session. The session will last until the maximum programmed Session Length is achieved or the TPI wire contact opens again, whichever comes first. While in TPI mode the timer will display "3P" if either timer button is pressed.

The Timer will remain in TPI mode even after power and the TPI cable have been removed. See the Operation Instructions for your timer revision to deactivate the TPI mode.

# Hookup

**Figure 2**  
**Hookup with a TanTime™ System™ Controller**

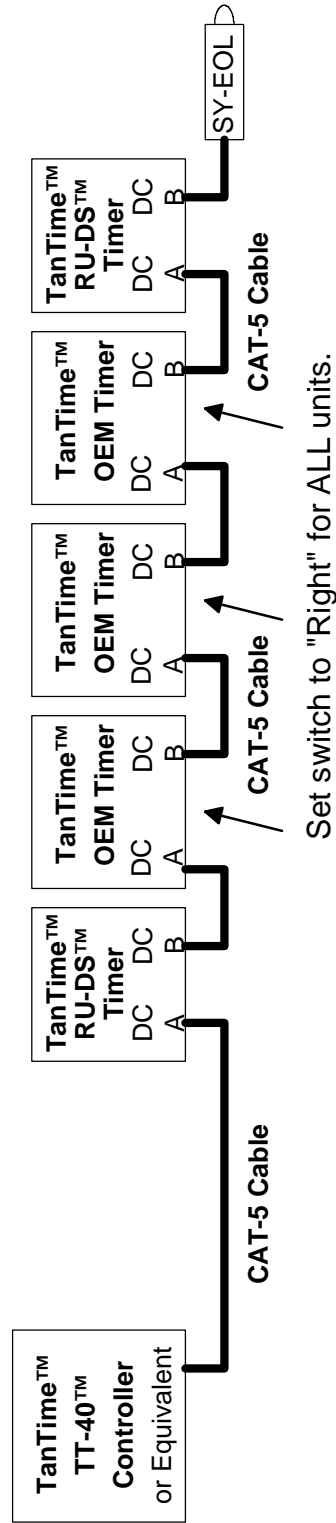

NOTE: Install an End Of Line Terminator in the last timer in the daisy chain per the instruction given in this manual.

DC A and DC B are abbreviations for Daisy Chain A and Daisy Chain B.

**Figure 3**

**Hookup for Sysstem™ Timers to T-Max® or Intellitan® Front Room Controllers**

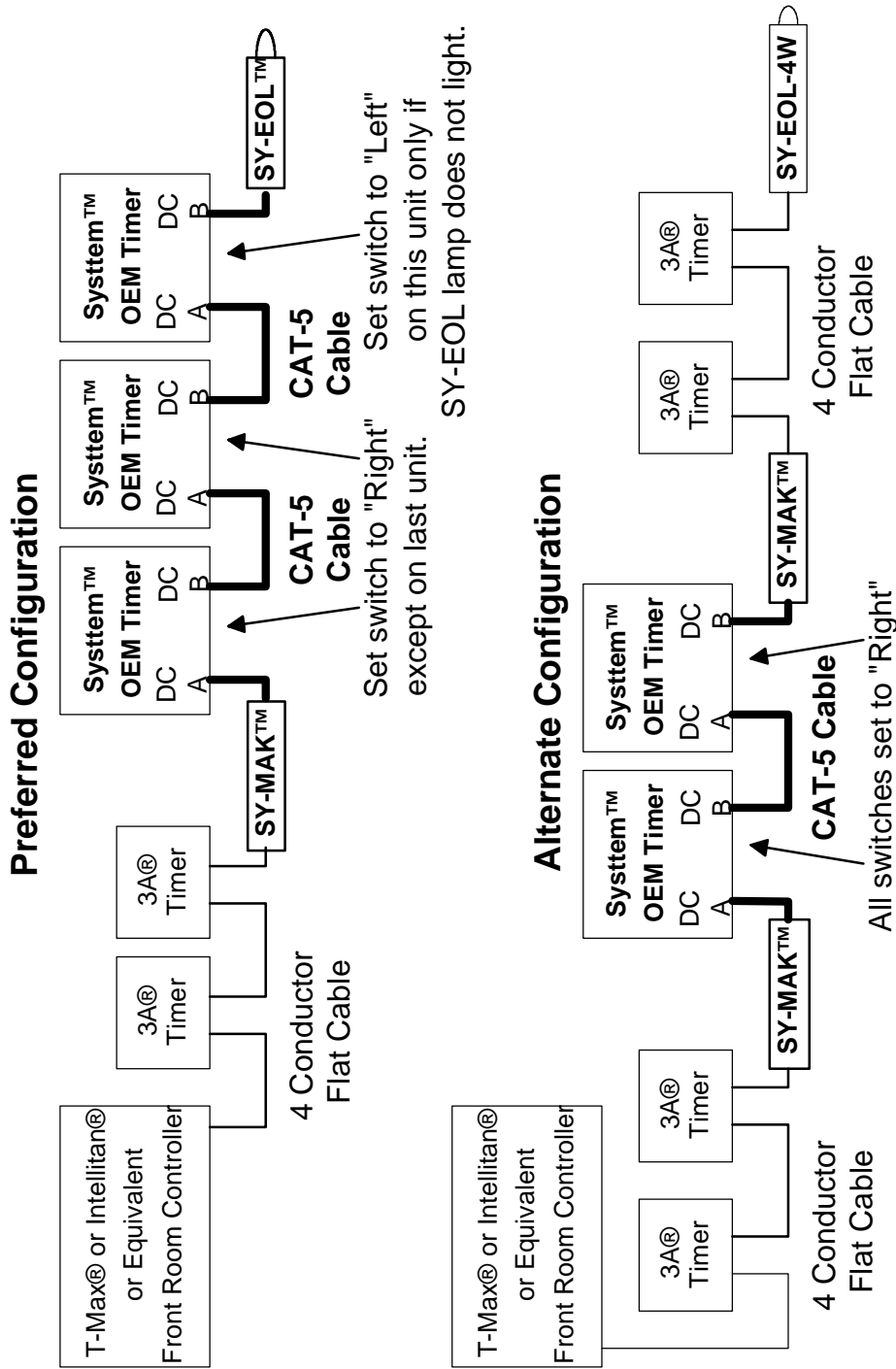

**Hookup**

T-Max®, and 3A® are registered trademarks of Applied Digital, Inc. (ADI) and are in no way associated with TanTime™. Intellitan® is a registered trademark of Sun Ergoline, Inc. and is in no way associated with TanTime™. DC A and B are abbreviations for Daisy Chain A and B.

# Hookup

## Connecting the OEM Timer to a Master Timer

A single System™ OEM timer may be remotely controlled by another timer configured as a Master Controller. The System™ OEM timer will operate as a slave to the Master Controller. See your Timer Operation Instructions for setup and operation.

If the Master Controller is a TanTime™ RU-DS™ or SY-TT-1™ Timer, use Cat-5 Cable to connect the two timers together. The Master Controller does not need a separate power supply as it may be powered by sliding the OEM timer switch to the **Left** (on) position. This will supply power to the Master Controller through the Cat-5 cable. (See Figure 4 for using a SY-TT-1™ Timer as the Master Controller.)

If the master controller is a RU-XM™, or a timer supplied by T-Max® or Intellitan® you must use a SY-MAK™ Multipurpose Adapter Kit to connect to the Master Controller. The Master Controller will need to be powered separately.

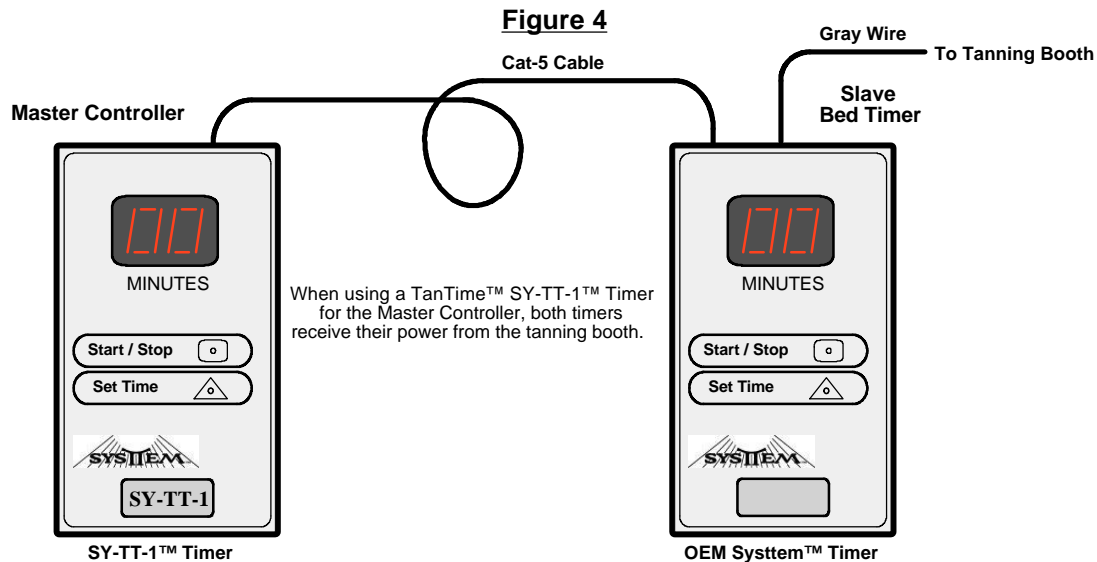

## Operation

Operation instructions for this Timer are found in "Room Unit & OEM Unit Timer Operation Instructions", TanTime™ document number DOC40301. Refer to that document for all operational features and control instructions.

# Support

## **The Company**

Since 1994, TanTime™, a Division of Electronic Programming and Design, Inc. Has been developing and manufacturing enhanced digital timer systems for the indoor tanning industry.

TanTime™ continually accesses the most innovative design technology available incorporating state of the art technology in all it's Products. As an industry leader, TanTime™ updates and adds new products to it's growing line of digital timers and strives for complete customer satisfaction by providing a quality product and unsurpassed customer support.

## **Support**

### **TanTime™ Dedication**

TanTime™ is dedicated to ensuring that you receive the best customer support and technical assistance possible. To ensure that you receive the most efficient help possible, please be ready to produce model numbers of the TanTime™ equipment in concern and product part numbers. For repairs and returns please be prepared to produce date of purchase, name of original purchaser, and PO Number. An RMA is required for all returns including both repairs and return-for-credit equipment returns.

### **Contact Us**

**Telephone:** Call TanTime™ / EPaD™ at **206-767-7262** Pacific Time M-F 9 AM to 5 PM, PST

**Email:** TanTime™ Technical Support: **info@tantime.com**

### **Returns and Repairs:**

#### **NOTE:**

A Return Merchandise Authorization (RMA) number must be obtained from TanTime™ prior to shipping equipment to us for repair or return. The customer is responsible for all shipping costs.

To be issued an RMA Number Call TanTime™ at 206-767-7262, M-F, 9 AM to 5 PM, PT.

### **Shipping / Mailing Address:**

You will receive the shipping address when obtaining your RMA number.

#### **Sales - Ordering Additional Equipment:**

**Telephone:** Call TanTime™ at 206-767-7262, Pacific Time, M - F, 9A - 5P.

**Email:** info@tantime.com

**Visit Web Site:** www.tantime.com